

detail A

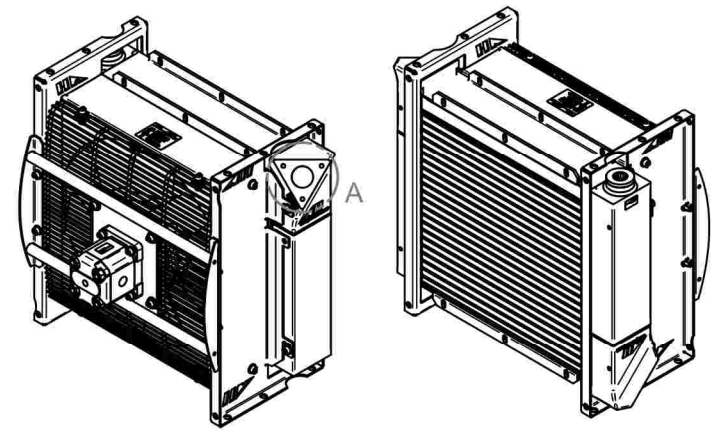

Limit for imperfections in welding joints according to ISO 10042, quality level "D".  
This is especially, but not exclusively true for weld upsets  
(ref. No. 502 according to ISO 6520)

For all dimensions which are depending on the brazing and welding process  
the free size tolerance DIN ISO 2768-v is valid

This drawing and attached written disclosure, if any, is our intellectual property and must not be used or disclosed to third parties without our explicit consent. All rights reserved. Diese Unterlage ist unser Eigentum und darf ohne unsere Zustimmung nicht weiterverleihen oder an Dritte weitergegeben werden. Alle Rechte vorbehalten.		free size tolerance <b>DIN ISO 2768-c</b>	surface	scale 1:5	weight 35,8 kg
ASA-Hydraulik Ges.m.b.H. A-1210 Wien		date	name	item number(s): <b>ASA0177AH22BP</b>	
drawn	01.09.16	KA	description <b>ASA 0177 22cm<sup>3</sup> Hydromotor BP</b>		
check sb	06.12.16	ML	drawing number		
review	06.12.16	NM	page 1		
release	06.12.16	JF	of. pgs.		
index	modification	date	name	drawing file: <input type="checkbox"/> BC <input type="checkbox"/> MC <input type="checkbox"/> MTC update: ERP.:	

