

Double solenoid valve
Rp 2 (DN 50)
DN 65 - DN 125
nominal diameters

DUNGS®
Combustion Controls

DMV/11 eco
DMV-D/11 eco
DMV-DLE/11 eco

7.38

neovità
nouveau
new

- Low power consumption
- Low weight
- Compact design
- High flow rates
- Max. operating pressure
500 mbar (50 kPa)



Technical description

The DUNGS double solenoid valve DMV integrates two solenoid valves in one compact fitting.

- Automatic shut-off valves as per DIN EN 161 Class A Group 2.
- Two A valves in one housing
- Double seat valves
- High flow rates
- Max. operating pressure up to 0.5 bar (50 kPa)
- Fast closing
- Fast opening (DMV/11 eco, DMV-D/11 eco)
- Adjustable main volume (DMV-D/11 eco, DMV-DLE/11 eco)
- DC solenoid
- Low electric power consumption through power switching
- Mountable closed position signal contact
- Compact, light-weight

Application

Double solenoid valves are used where two single valves were mounted previously. In connection with DUNGS gas regulators and additional components, a wide variety of regulating tasks can be performed.

It does not contain any non-ferrous metals, suitable for gases of up to max. 0.1 vol.% H₂S, dry. Suitable for gases of families 1, 2, 3 and other neutral gaseous media.

Approvals

EC type test approval as per EC Gas Appliance Directive:

DMV-...525-5125/11 eco CE-0085 AN 2801

EC type test approval as per EC Pressure Equipment Directive:

DMV-...525-5125/11 eco CE0036

Approvals in other important gas consuming countries.

Specifications

Nominal diameters Flange	DN 65 80 100 125 Connection flange as per DIN 2501 Part 1, to fit preweld flanges as per DIN 2633 (PN 16) DN 65 to DN 125, ISO 7005 - 1 (PN 16), ISO 7005 - 2 (PN 16) Construction length as per DIN 3202 Part 1, row F1 for DN 65 to DN 125																														
Nominal diameters Flange with pipe thread as per ISO 7-1	DMV 525/11 eco Rp 2																														
Max. operating pressure	500 mbar (50 kPa)																														
Solenoid valve V1	Automatic shut-off valve as per EN 161: Class A, Group 2																														
Solenoid valve V2	Automatic shut-off valve as per EN 161: Class A, Group 2																														
Closing time	< 1 s																														
Opening time	DMV.../11 eco, DMV-D.../11 eco: < 1 s																														
Main valve restrictor	Adjustable (DMV-D.../11 eco, DMV-DLE.../11 eco)																														
Materials of gas conveying parts	Housing: aluminium, steel, no non-ferrous metals Seals at valve seat: NBR basis, suitable for gases as per G260/I FKM basis, suitable for gases as per G260/I (Viton version)																														
Ambient temperature	NBR: -15 °C to +60 °C Viton: 0 °C to +60 °C																														
Installation position	Solenoid vertically upright to lying horizontally																														
Dirt trap	Sieve installed. To protect the complete gas train we recommend you to install a suitable gas filter (refer to Datasheet 11.02)																														
Measuring gas connection	G 1/4 DIN ISO 228 centrally upstream of V1 and downstream of V2 (not 525/11 eco) G 1/8 DIN ISO 228 on both sides upstream of V1, between V1 and V2, downstream of V2																														
Ignition gas connection	G 3/4 ignition gas flange as per ISO 228, possible on both sides between V1 and V2																														
Voltage/frequency	50 - 60 Hz, 230 V AC, -15% +10%, further voltages on request Other preferred voltages: 110 V AC, 24 V DC																														
Rating / power consumption at 230 V AC, + 20°C all indications are effective values	<table border="1"> <thead> <tr> <th>Version</th> <th>Starting power approx. [W]</th> <th>Holding power approx. [W]</th> <th>Break-away starting current [A]</th> <th>Holding current [A]</th> </tr> </thead> <tbody> <tr> <td>DMV 525/11 eco</td> <td>2 x 65</td> <td>2 x 16</td> <td>2 x 0.32</td> <td>2 x 0.11</td> </tr> <tr> <td>DMV... 5065/11 eco</td> <td>2 x 65</td> <td>2 x 16</td> <td>2 x 0.32</td> <td>2 x 0.11</td> </tr> <tr> <td>DMV... 5080/11 eco</td> <td>2 x 95</td> <td>2 x 20</td> <td>2 x 0.54</td> <td>2 x 0.20</td> </tr> <tr> <td>DMV... 5100/11 eco</td> <td>2 x 125</td> <td>2 x 25</td> <td>2 x 0.54</td> <td>2 x 0.20</td> </tr> <tr> <td>DMV... 5125/11 eco</td> <td>2 x 125</td> <td>2 x 25</td> <td>2 x 0.54</td> <td>2 x 0.20</td> </tr> </tbody> </table>	Version	Starting power approx. [W]	Holding power approx. [W]	Break-away starting current [A]	Holding current [A]	DMV 525/11 eco	2 x 65	2 x 16	2 x 0.32	2 x 0.11	DMV... 5065/11 eco	2 x 65	2 x 16	2 x 0.32	2 x 0.11	DMV... 5080/11 eco	2 x 95	2 x 20	2 x 0.54	2 x 0.20	DMV... 5100/11 eco	2 x 125	2 x 25	2 x 0.54	2 x 0.20	DMV... 5125/11 eco	2 x 125	2 x 25	2 x 0.54	2 x 0.20
Version	Starting power approx. [W]	Holding power approx. [W]	Break-away starting current [A]	Holding current [A]																											
DMV 525/11 eco	2 x 65	2 x 16	2 x 0.32	2 x 0.11																											
DMV... 5065/11 eco	2 x 65	2 x 16	2 x 0.32	2 x 0.11																											
DMV... 5080/11 eco	2 x 95	2 x 20	2 x 0.54	2 x 0.20																											
DMV... 5100/11 eco	2 x 125	2 x 25	2 x 0.54	2 x 0.20																											
DMV... 5125/11 eco	2 x 125	2 x 25	2 x 0.54	2 x 0.20																											
Degree of protection / switch-on duration	IP 54 / 100 %																														
Electrical connection	Plug-in connection as per DIN EN 175301-803																														
Radio interference	Degree of interference N																														
Closed position signal contact	Type K01/1 (DIN tested), can be mounted on V1 and V2																														

Dimensions for DMV.../11 eco

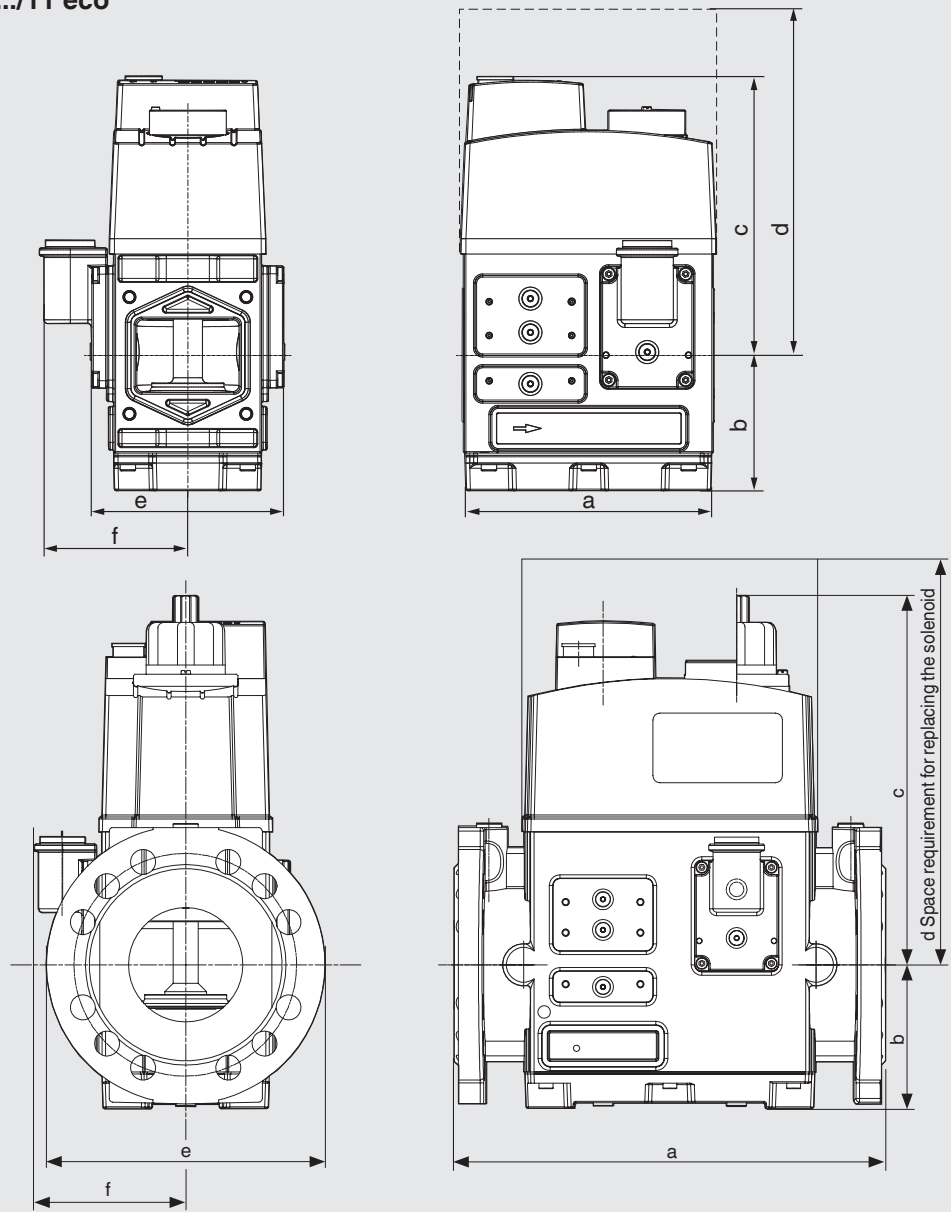

Version	Order No.	p _{max.} [bar]	Conne- ction DN	Dimensions [mm]						Solenoid No.	Swit- ching rate/h ¹⁾	Weight [kg]
				a	b	c	d	e	f			
DMV 525/11 eco	256 139	0.5	Rp 2 (DN 50)	162	88	179	275	125	97	1411/2P	60	7.2
DMV 5065/11 eco	256 293	0.5	DN 65	290	88	179	275	185	97	1411/2P	60	10.0
DMV 5080/11 eco	256 356	0.5	DN 80	310	104	246	370	200	109	1511/2P	60	16.3
DMV 5100/11 eco	249 774	0.5	DN 100	350	119	292	450	220	116	1611/2P	60	24.2
DMV 5125/11 eco	250 465	0.5	DN 125	400	142	329	500	255	125	1711/2P	60	31.7
DMV-D 525/11 eco	256 151	0.5	Rp 2 (DN 50)	162	88	179	275	125	97	1411/2P	60	7.2
DMV-D 5065/11 eco	256 296	0.5	DN 65	290	88	179	275	185	97	1411/2P	60	10.0
DMV-D 5080/11 eco	256 357	0.5	DN 80	310	104	246	370	200	109	1511/2P	60	16.3
DMV-D 5100/11 eco	253 459	0.5	DN 100	350	119	292	450	220	116	1611/2P	60	24.2
DMV-D 5125/11 eco	253 461	0.5	DN 125	400	142	329	500	255	125	1711/2P	60	31.7
DMV-DLE 525/11 eco	256 172	0.5	Rp 2 (DN 50)	162	88	179	275	125	97	1411/2PL	20	7.2
DMV-DLE 5065/11 eco	256 297	0.5	DN 65	290	88	179	275	185	97	1411/2PL	20	10.0
DMV-DLE 5080/11 eco	256 358	0.5	DN 80	310	104	265	370	200	109	1511/2PL	20	16.5
DMV-DLE 5100/11 eco	256 458	0.5	DN 100	350	119	346	450	220	116	1611/2PL	20	24.5
DMV-DLE 5125/11 eco	256 459	0.5	DN 125	400	142	387	500	255	125	1711/2PL	20	32.0

¹⁾ Switching rate of DMV-DLE.../11 eco depends on opening time setting



Important: Always order, plug connection and system accessories separately.

3 ... 6 accessories separately.

DMV/11 eco	Two single stage solenoid valves, de-energised in absence of current, fast-opening, fast-closing.
DMV-D/11 eco	Two single stage solenoid valves, de-energised in absence of current, fast-opening, fast-closing. Manual limitation of gas flow is possible with main load adjustment (D) at valve 1 (V1).
DMV-DLE/11 eco	Two single stage solenoid valves, de-energised in absence of current, slow-opening (L), fast-closing. Adjustment of opening time (E) with fast stroke range at valve 2 (V2). Manual limitation of gas flow is possible with main load adjustment (D) at valve 1 (V1).

Variants Double solenoid valve DMV-.../11 eco single stage operating mode	DMV/11 eco Rp 2 (DN 50)	DMV/11 eco DN 65 - DN 125
DMV	◆	◆
DMV-D	◆	◆
DMV-DLE	◆	◆
Filter	◆	◆
Gas pressure switch can be mounted:		
on the flange	◆	(◆)
after the filter, before V1	◆	◆
between V1 and V2	◆	◆
after valve 2	◆	◆
valve V1, double seat	◆	◆
valve V2, double seat	◆	◆
Valves open separately	◆	◆
Ignition gas flange G 3/4	◆	◆

◆ = standard
(◆) = on request
-- = not possible

Double solenoid valve modular system

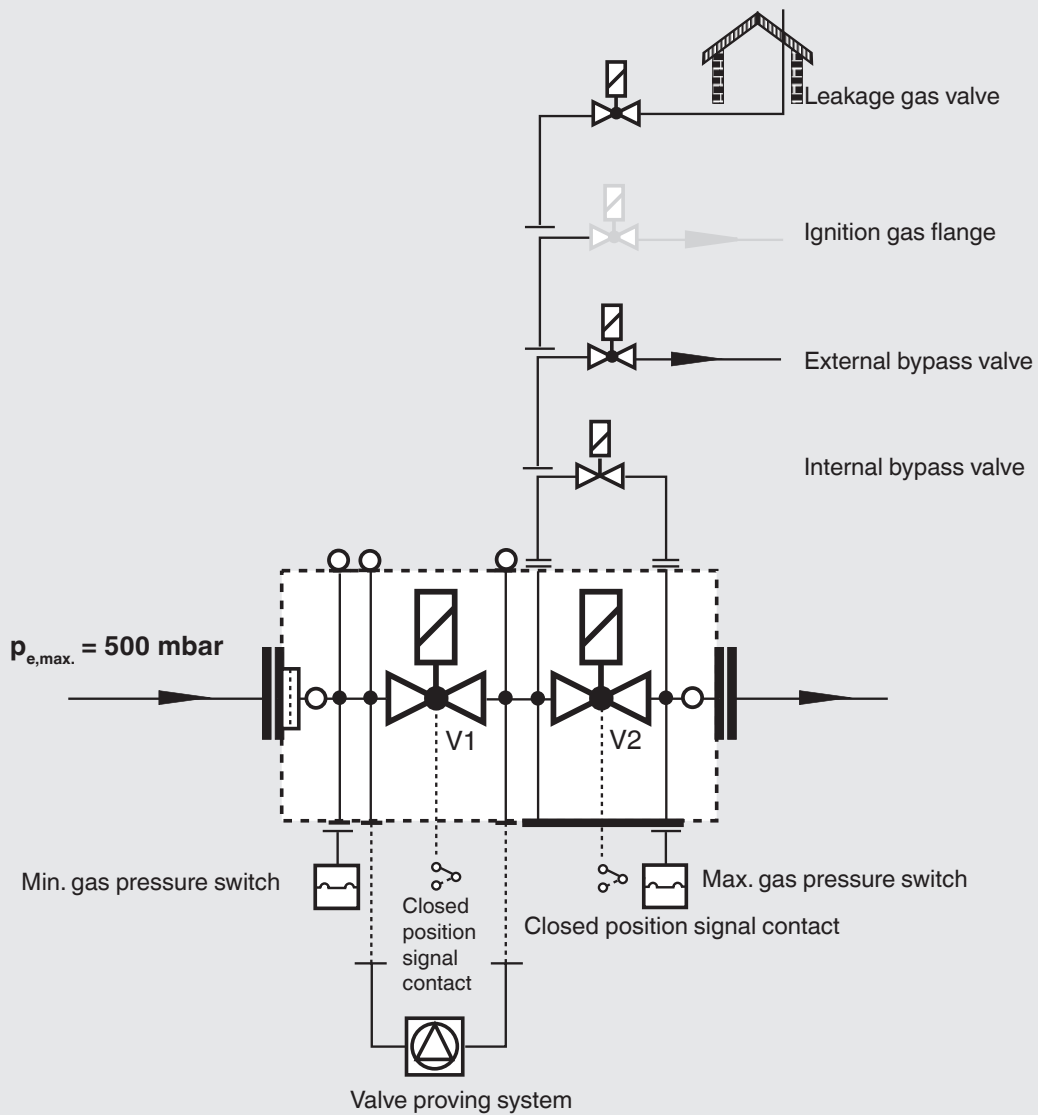

System accessories

The double solenoid valve is prepared for direct mounting of **DUNGS** system accessories and additional equipment.

Compact pressure switch for multiple actuators GW...A5

Datasheet 5.02

 If a system accessory is added, it may not be possible to mount further devices.

Information on system accessories

K01/1 closed position signal contact to monitor closed position of valves

Datasheet 12.01

VPS 504 valve proving system

Datasheet 8.10

Pressure limiter ÜB, NB...A2 for multiple actuators

Datasheet 5.08

Double solenoid valve
Rp 2 (DN 50)
DN 65 - DN 125
nominal diameters

DMV/11 eco
DMV-D/11 eco
DMV-DLE/11 eco



Flow diagram

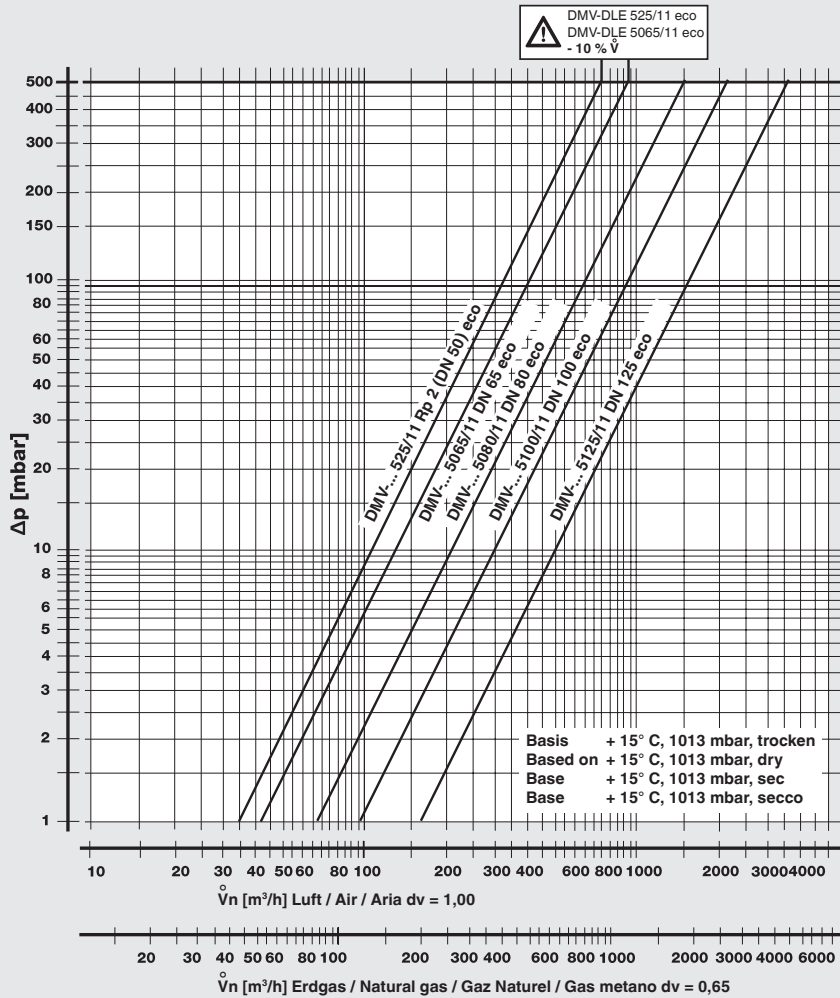

$$f = \sqrt{\frac{\text{Dichte Luft} / \text{Dichte des verwendeten Gases}}{\text{Spec. weight air} / \text{Spec. weight of gas used}}}$$

Dichte Luft
 Spec. weight air
 poids spécifique de l'air
 peso específico aria
 Dichte des verwendeten Gases
 Spec. weight of gas used
 poids spécifique du gaz utilisé
 peso específico del gas utilizado

Gas type	Spec. Wgt. [kg/m³]	dv	f
Nat. gas	0.81	0.65	1.24
City gas	0.58	0.47	1.46
LPG	2.08	1.67	0.77
Air	1.24	1.00	1.00

$$\overset{\circ}{V}_{\text{verwendetes Gas/gas used/gaz utilisé/gas utilizzato}} = \overset{\circ}{V}_{\text{Luft/air/aria}} \times f$$

We reserve the right to make any changes in the interest of technical progress.

Head Offices and Factory
Karl Dungs GmbH & Co. KG
Siemensstraße 6-10
D-73660 Urbach, Germany
Telephone +49 (0)7181-804-0
Fax +49 (0)7181-804-166

Postal address
Karl Dungs GmbH & Co. KG
Postfach 12 29
D-73602 Schorndorf, Germany
e-mail info@dungs.com
Internet www.dungs.com